

Outdoor Dimming Driver

GED150MC/VD1P1050S; SAP: 95014246; PC: 37324

GED150MC/VD1P700S; SAP: 95014247PC: 37323

Description: 150W 0.7/1.05A DALI/Dimmable/Programmable PSU

Description: 150W 0.3/0.7A DALI/Dimmable/Programmable PSU

Input Voltage: 120V/277V

Input Frequency: 50/60Hz

ROHS Compliant: Yes

| Max Output Power (W) | Output Current (A) | Output Voltage (V) | Efficiency Full load | Max Input Current (A) | Max THD @68W Output | Min PF @120V/ 68W @230V/ 68W @277V/ 90W | Max Inrush Current (A) | Surge Protection (kV/kA) | Isolated Dimming | | | Weight (lbs/kg) | IP Rating | |
|----------------------|----------------------------|--------------------|----------------------|------------------------|---------------------|---|------------------------|--------------------------|------------------|----------------|--------------------------|-----------------|-----------|------|
| | | | | | | | | | Protocol | Current Source | Dimming Range @full load | | | |
| 150 | Programmable, max 0.7-1.05 | 70-215 | >90% | 1.5 @120V 0.6 @277V | 20% | >0.9 | 60 | 10 / 5 | DALI | 0-10V | 0.5mA | 100%-10% | 0.9Kg | IP66 |
| 150 | Programmable, max 0.3-0.7 | 100-290 | >90% | 1.5 @120V 0.6 @277V | 20% | >0.9 | 60 | 10 / 5 | DALI | 0-10V | 0.5mA | 100%-10% | 0.9Kg | IP66 |

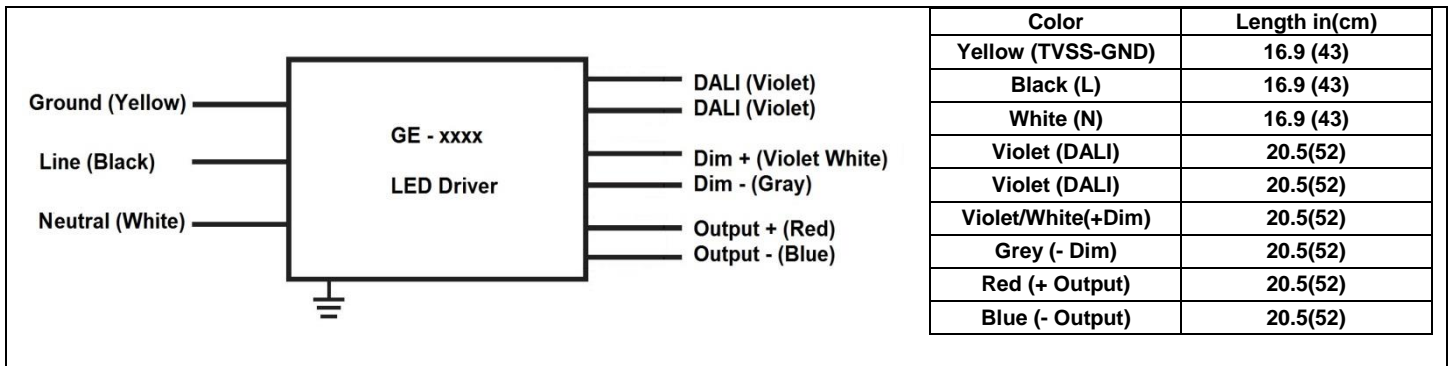

Physical

- Unit must be installed within an electrical enclosure.
- Enclosure wiring must be rated to 600V & 105°C or higher.

Performance

- The unit is classified as Class 1 as stipulated in UL8750.
- Dimming circuit is classified as Class 2 as stipulated in UL1310.
- Minimum ambient operating temperature: -40°C.
- Maximum allowable case temperature: 85°C.
- For reliability and failure rate information, contact LED Outdoor Electronics Team
- Thermal overload protected Drivers. The unit will reduce output current if the case temperature exceeds 85°C.
- The unit is UL certified for operation in dry/damp locations (Outdoor Type 1).
- The unit is tolerant of extended open circuit and short circuit conditions.
- The unit is compliant to FCC Title 47 Part 15 Class A
- The unit is resistant to surges as per IEEE/ANSI C136.2-2015 Location C (10kV/5kA) and EN61000-4-5:2006 (10kV/5kA)

Programmable Features

- Output current
- Dimming Level
- Constant Light Output
- Clock Dimming

UL Conditions of Acceptability – E340135

- The unit has been examined to comply with Class 1 Output Criteria
- The unit is only to be used in dry or damp locations
- The metal case must be connected to **EARTH**.
- TVSS-GND (Yellow wire) shall be connected to fixture ground after hi-pot test using closest tab screw. **THIS IS NOT A SAFETY GROUND!**

Technical Information

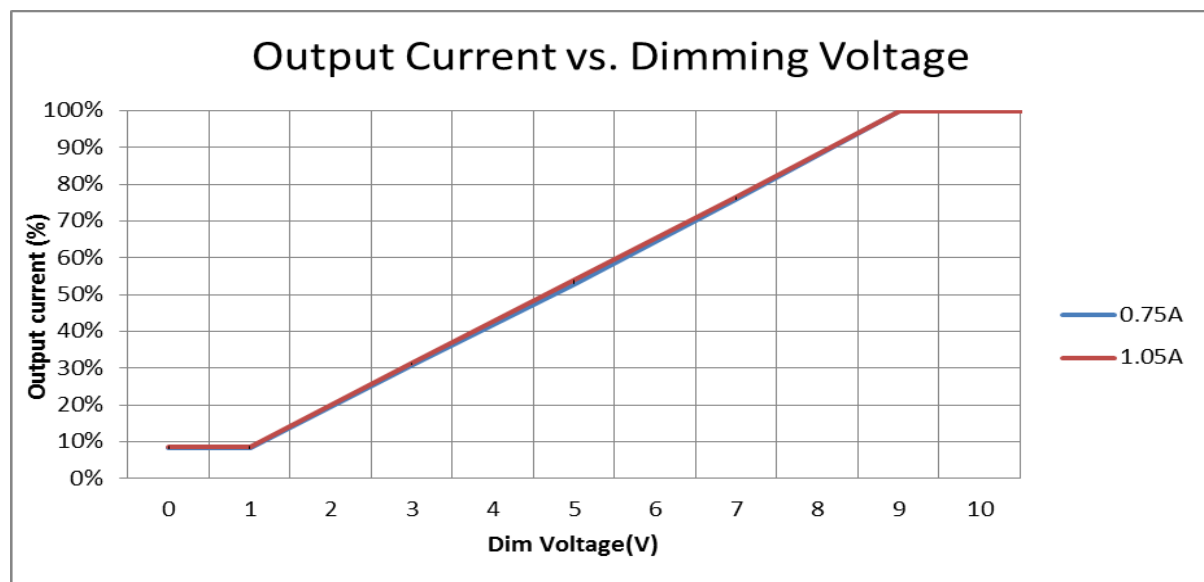
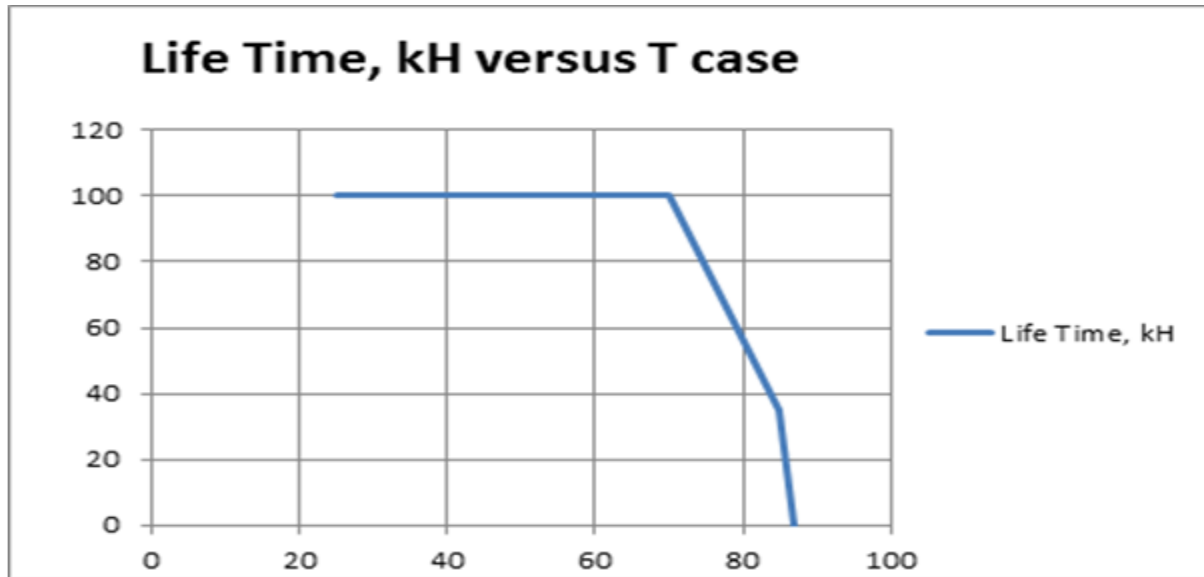

Efficiency versus Output Power 0.3/0.7A

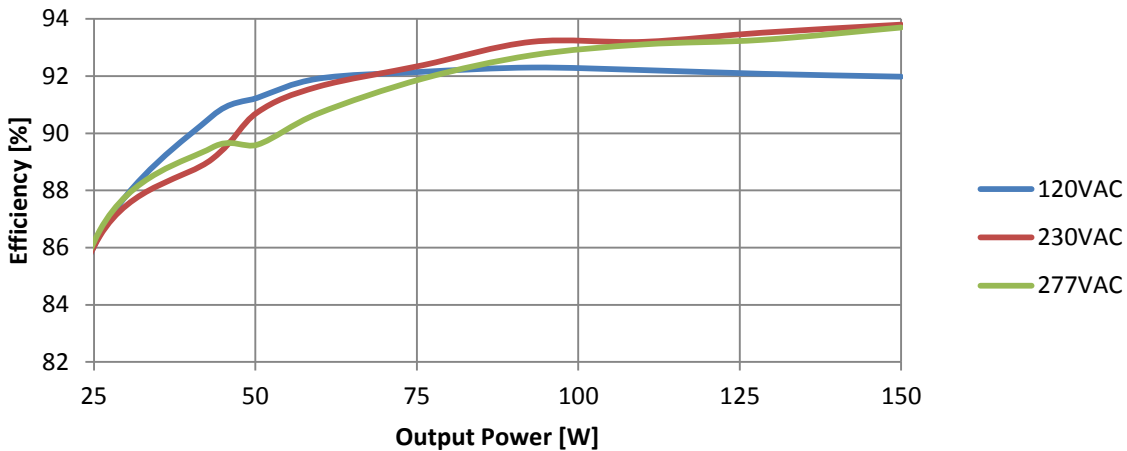

Efficiency versus Output Power 0.7/1.05A

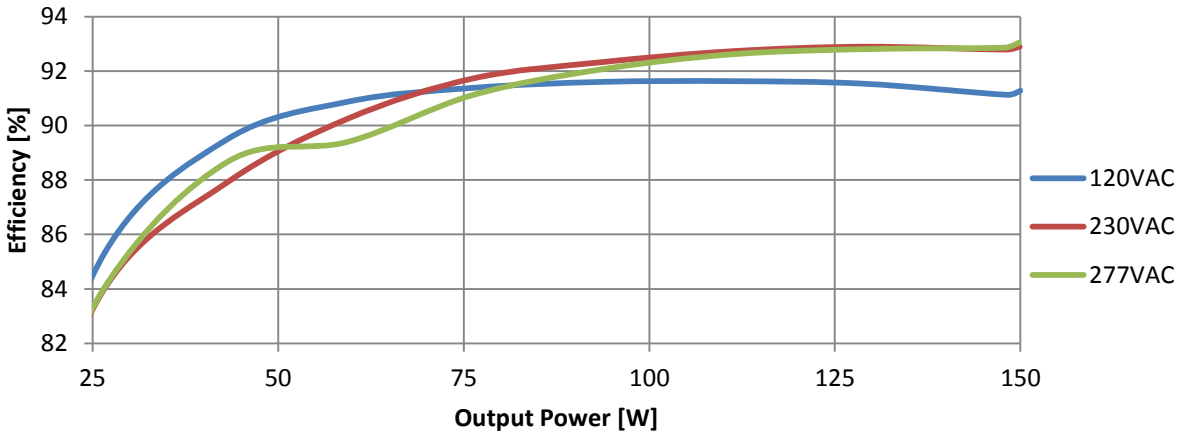

Note: LED Load was used. Power variation was made by dimming.

THD versus Output Power

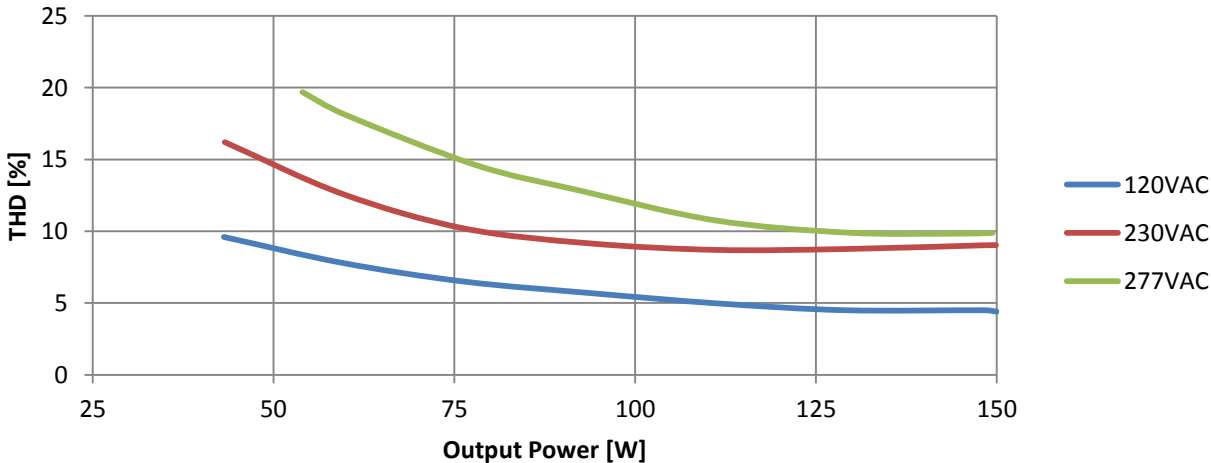

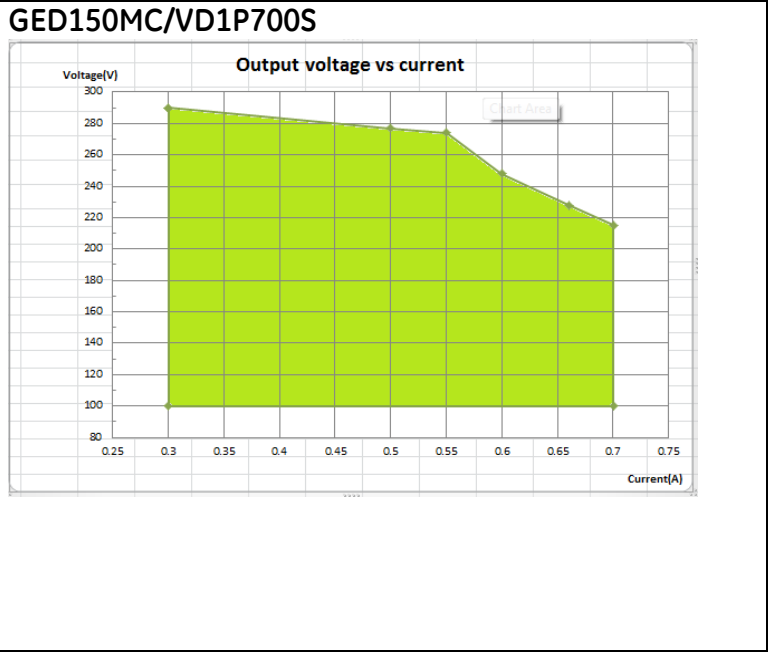
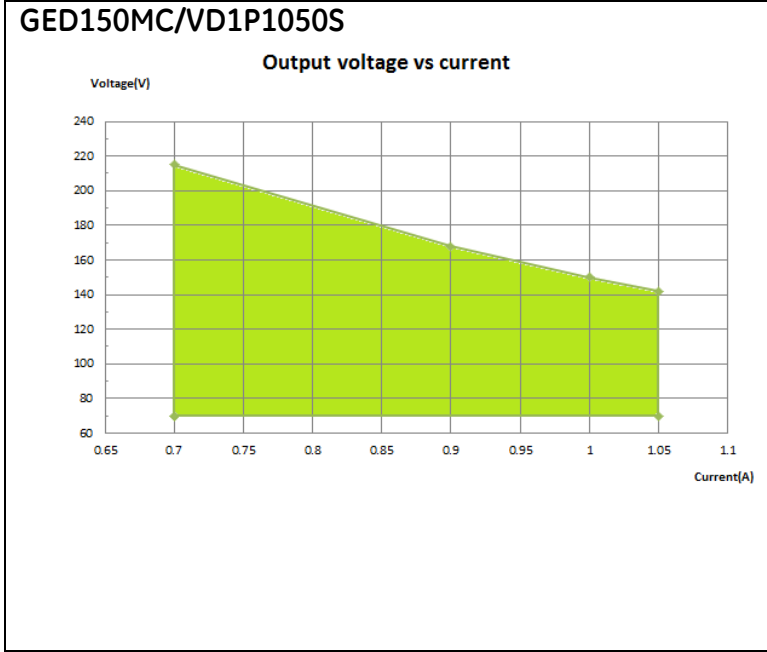
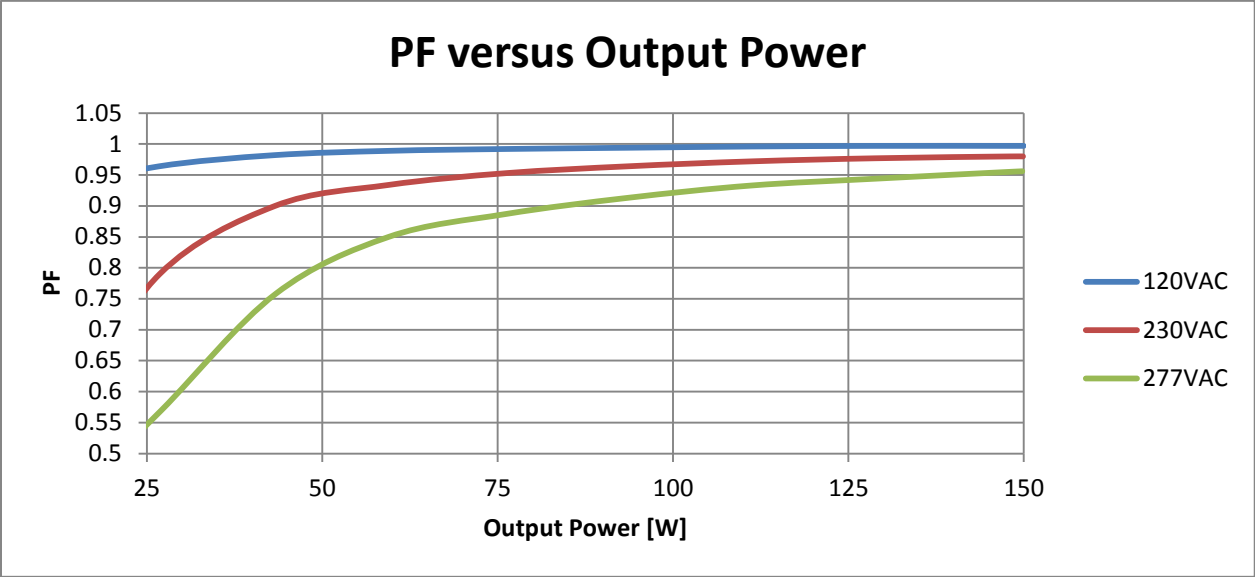





| Input Inrush Current | | |
|--------------------------------------|--|--------------------------------------|
| Input Voltage [V _{rms}] | Peak Current Pulse [A _{pk}] | Pulse Duration (50% of Peak) [ms] |
| 277 | 118 | 0.1 |

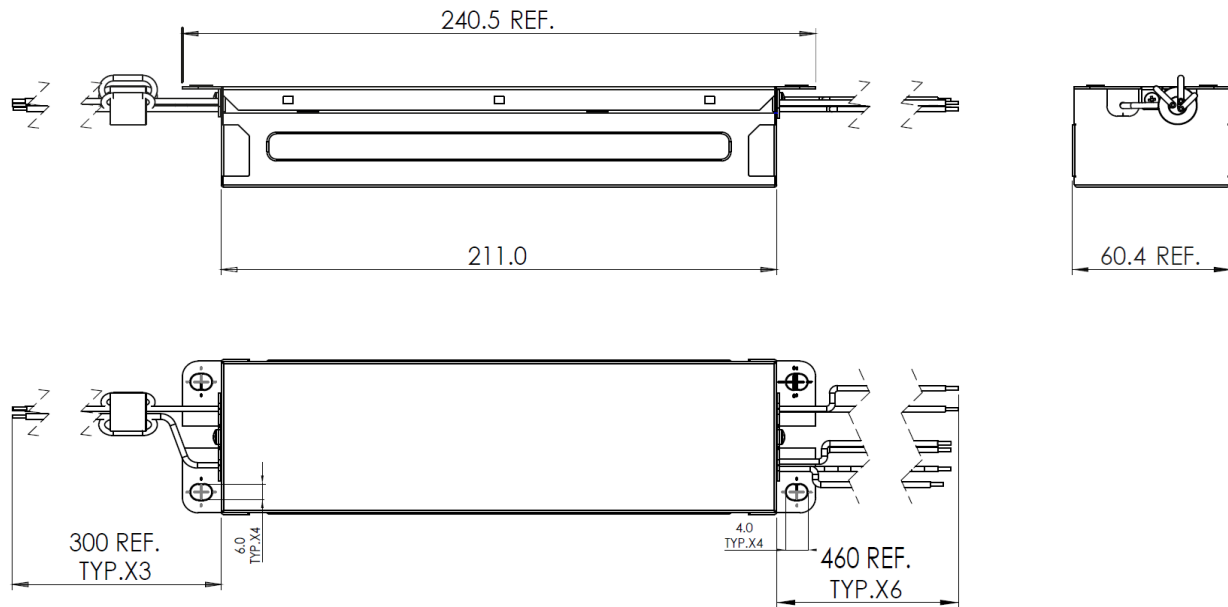



| Input Ground Leakage Current | |
|--------------------------------------|-------------------------|
| Input Voltage [V _{rms}] | Leakage Current [mA] |
| 240, 60Hz | 0.56 |

Product Dimensions

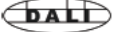

Product Label Example

| | | | |
|--|---|--|--|
|  <p>UltraMax™ Programmable LED Driver</p> <p>GED150MC/VD1P1050S PC:37324 SAP:95014246</p>  <p>37324</p> | <p>INPUT Voltage 120-277 VAC 50/60 Hz Current 1.5 Amps PF>0.95</p> <p>OUTPUT 280VDC Max 1050mA Max Output 150 Watts</p> <p>22mm 135mm BOTTOM SIDE 85°C t_v=50°C</p> <p>Class 1 Power Supply</p> <p>White (L) Black (N) Yellow (TVSS)</p> <p>SCHR</p> <p>DALI DIM OUT</p> <p>Violet Violet Violet White(+) Gray(-) Red (+) Blue (-)</p> <p>S/N</p> <p>WARNING / AVERTISSEMENT Risk of electrical shock. Disconnect power before servicing or installing product. Risque de choc électrique. Couper l'alimentation avant le dépannage ou avant l'installation du produit.</p> | <p>120-277V DALI and 0-10v Dimmable LED Driver Min Start Temp -40°C Thermal Protection Protection Thermique Class 1 Firmware U7 Firmware U6 FCC Part 15, Non-Consumer High Power Factor Sound Rated A</p> <p>Product is compliant with material restriction requirements of RoHS. Install and ground per National Electric Code For Dry or Damp Locations</p> | <p>Made in China, Designed & Distributed by General Electric Co. GE Lighting Nela Park, Cleveland, Ohio 44112</p>   <p>For assistance call: 1-888-MYGELED</p> |
|--|---|--|--|

| | | | |
|--|--|---|--|
|  <p>UltraMax™ Programmable LED Driver</p> <p>GED150MC/VD1P700S PC:37323 SAP:95014247</p>  <p>37323</p> | <p>INPUT Voltage 120-277 VAC 50/60 Hz per UL Current 1.5 Amps per UL PF>0.95</p> <p>OUTPUT 360VDC Max 700mA Max Output 150 Watts</p> <p>22mm 135mm BOTTOM SIDE 85°C t_v=50°C</p> <p>Power Supply</p> <p>Yellow (TVSS) Black (L) White (N)</p> <p>SCHR</p> <p>DALI DIM OUT</p> <p>Violet Violet Violet White(+) Gray(-) Red (+) Blue (-)</p> <p>S/N</p> <p>WARNING / AVERTISSEMENT Risk of electrical shock. Disconnect power before servicing or installing product. Risque de choc électrique. Couper l'alimentation avant le dépannage ou avant l'installation du produit.</p> | <p>120-277V DALI and 0-10v Dimmable LED Driver Min Start Temp -40°C Thermal Protection Protection Thermique Class 1 per UL Firmware U7 Firmware U6 FCC Part 15, Non-Consumer High Power Factor Sound Rated A</p> <p>Product is compliant with material restriction requirements of RoHS. Install and ground per National Electric Code For Dry or Damp Locations</p> | <p>Made in China, Designed & Distributed by General Electric Co. GE Lighting Nela Park, Cleveland, Ohio 44112</p>   <p>For assistance call: 1-888-MYGELED</p> |
|--|--|---|--|

Current Programming Interface

Firstly open the software(DALI_NEW_API) and click the Bank2 sheet, then put the value to be programmed (between 0 to 100%) into the Value box for Current to Program of Bank 2 GE Use , finally click the set button to complete the programming of driver.

The screenshot shows the 'Bank 2' tab selected in the software interface. The 'Bank 2 GE Use' section contains the following fields and controls:

| | Value | HEX |
|---|-------|------|
| Address of last accessible memory location: | 9 | 0x09 |
| Check Sum: | 0xB0 | 0xB0 |
| Lock Byte: | 170 | 0xAA |

| | Value | HEX |
|----------------------|----------|---------------------|
| Current Programming: | 52 % | 0x02 0x1E |
| Default Power Value: | 16056470 | 0x00 0xF5 0x00 0x96 |

Device Mode:

- 0-10V mode
- DALI mode
- ClockDIMM mode

Buttons: Clear All, Read Bank 2, Set

Instructions:

- 1st. Click here
- 2nd. Set the current percentage you want
- 3rd. Choose the Dali mode or 0-10V mode
- 4th. Click the set button